



# 883

The high performance Terex Finlay 883 is designed to work after a primary crusher or on it's own as a frontline tracked mobile screening machine. Applications include quarrying, mining construction and demolition debris, topsoil, recycling, sand, gravel, coal and aggregates. The plant has the capacity to process at a rate of up to 500 tonnes per hour and can be fed either by a tracked mobile crusher or an excavator.

## Features:

- ▶ Aggressive screen box can accept bofor bars, speedharps woven mesh, punch plate, tines and cascade fingers.
- ▶ Modular configuration screen box with 4.8m x 1.5m (16' x 5') top deck and 3.65m x 1.5m (12' x 5') bottom deck screen.
- ▶ Screen box angle can be hydraulically adjusted to an angle between 13° to 19°.
- ▶ Screen box discharge end can be hydraulically raised 500mm to facilitate efficient and easy media access and changing.
- ▶ All stockpiling conveyors are hydraulic angle adjustable.

### Transport Dimensions

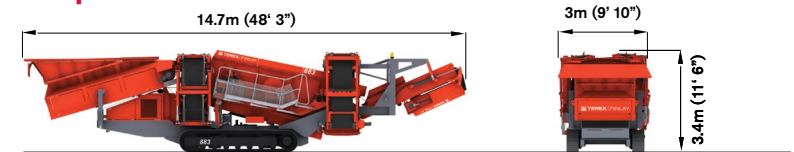

### Working Dimensions

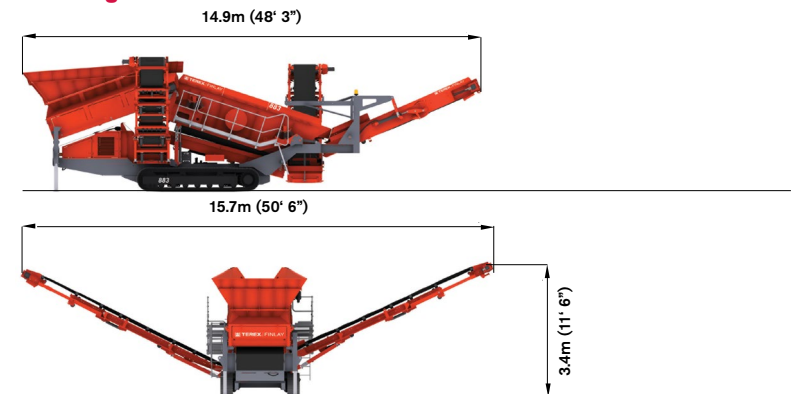

Maximum Plant Capacity:	tph**	Stph**
	500	551

\*\*Material is based on pit run sand/gravel with bulk density 1/6T/cu.mm Screening capacity depends upon mesh sizes and relates to dry screening in optimal material conditions.

Machine Weight: 32,000Kg (70,547lbs)\* \*Standard Machine configuration

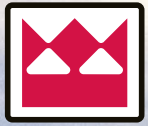

**TEREX® | FINLAY**

A large red Terex Finlay 883 Heavy Duty Screen is shown in operation at a quarry. The machine is processing dark red material, with a conveyor belt on the left and a discharge chute on the right. The background features a hilly landscape under a blue sky with scattered clouds. The number '883' is visible on the side of the machine.

# Heavy Duty Screen 883